



## DAB-8-4 Heavy Duty Benchtop Series

### General Overview

- Automation for OEM applications available
- Easy to set-up, operate, clean and fast changeovers
- Accomodates free-flowing, semi-viscous, viscous, molten products, and products with particulates
- Durable stainless steel structure
- Modular design with built-in expansion capability for production changes
- Heavy-Duty base frame with diving nozzles available
- CE Mark and explosion proof design available for hazardous environments



Unique Performance. Undeniable Quality. Unrivald Support.  
Go Further, Do More with FILAMATIC.

# DAB-8-4 Heavy Duty Benchtop Series

866.258.1914  
info@filamatic.com  
www.filamatic.com



## Technical Features

- Fill accuracy + / - 0.5%
- Optional diving nozzle mechanism available
- Product may be supplied from floor level, overhead, or a pressurized source depending on pump system
- Ability to fill a wide range of containers such as plastic and glass bottles, pouches, syringes, and test tubes
- USA designed, engineered, and manufactured filling systems

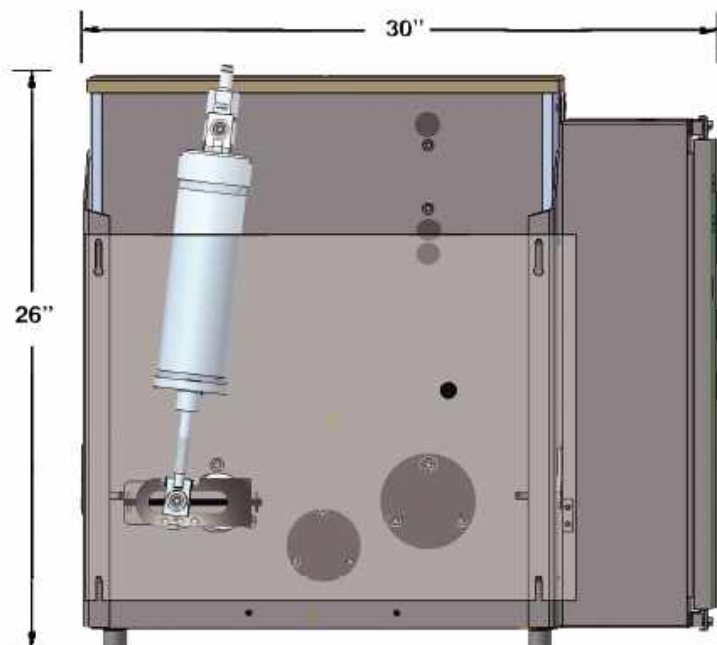

Model	Fill Stations	Volts	RPM	Fill Size
<b>DAB-8-4</b>	<b>4-12</b>	<b>110 - 220V</b>	<b>Up to 175</b>	<b>1mL to 260mL</b>

FILAMATIC

4119 Fordleigh Road • Baltimore, MD 21215  
866.258.1914 • [info@flamatic.com](mailto:info@flamatic.com) • [www.flamatic.com](http://www.flamatic.com)