



DAB-8-2 Heavy Duty Benchtop Series

General Overview

- Doubles the production rate when compared to our AB series model
- Filling speed adjustable from 16-174 cycles per minute
- Durable stainless steel structure
- Modular design with built-in expansion capability for production changes
- Heavy-Duty base frame with diving nozzles available
- Fill volumes from 1 ml to 260ml depending on the application



Unique Performance. Undeniable Quality. Unrivaled Support.
Go Further, Do More with FILAMATIC.

DAB-8-2 Heavy Duty Benchtop Series

866.258.1914
info@filamatic.com
www.filamatic.com



Technical Features

- Fill accuracy + / - 0.5%
- Optional diving nozzle mechanism available
- Product may be supplied from floor level, overhead, or a pressurized source depending on piston pump system selected
- Ability to fill a wide range of containers such as plastic and glass bottles, pouches, syringes, and test tubes
- USA designed, engineered, and manufactured filling systems

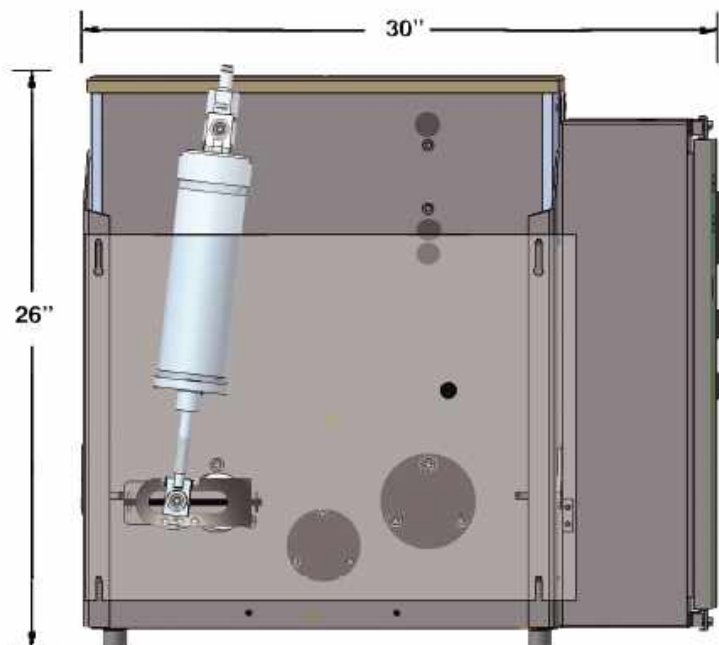

Model	Fill Stations	Volts	RPM	Fill Size
DAB-8-2	2	110 or 220V	Up to 175	1mL to 260mL

FILAMATIC

4119 Fordleigh Road • Baltimore, MD 21215
866.258.1914 • info@flamatic.com • www.flamatic.com