



Monobloc - Fill/Finish Packaging System

General Overview

- Ability to sort, feed, fill, plug, stopper crimp, cap, label, and/or accumulate in a compact footprint
- User-friendly, menu driven HMI touchscreen operator interface
- Quick and easy tool-less changeovers
- Standard laminar airflow design for cleanroom
- Servo-motor driven technology
- Optional HEPA filtration system available
- Recipe driven changeover
- Optional remote access



Unique Performance. Undeniable Quality. Unrivaled Power.
Go Further, Do More with FILAMATIC.

Monobloc - Fill/Finish Packaging System

866.258.1914
info@filamatic.com
www.filamatic.com



Technical Features

- Handles free-flowing to viscous products
- Fill accuracy: + / - 0.5%
- Fill volume range: 0.5ml to 500ml
- Choice of filling system: positive displacement, peristaltic, or micro-dose rotary piston
- Optional net weigh capability
- Optimally designed for cGMP/FDA Environments
- Optional mounted HEPA filtration hood
- Optional down stream labeler

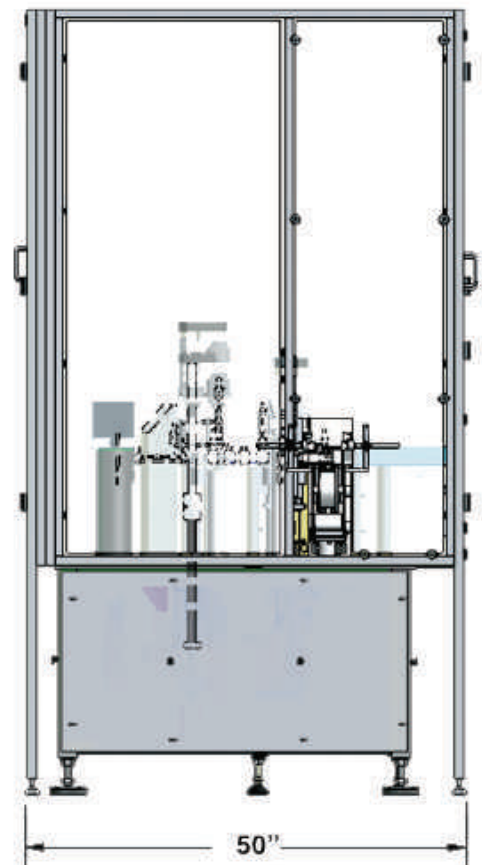
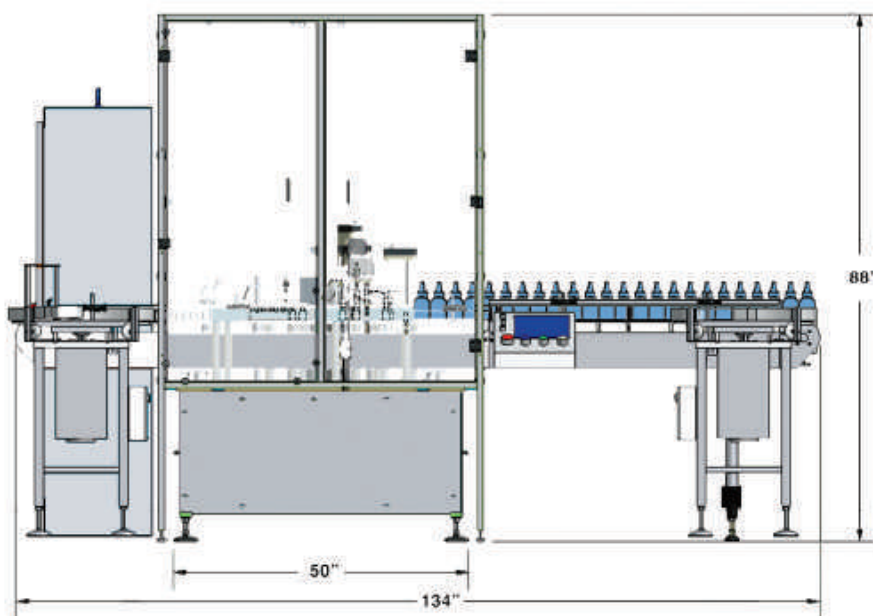

FILAMATIC

4119 Fordleigh Road • Baltimore, MD 21215
866.258.1914 • info@flamatic.com • www.flamatic.com