



## Mini-Monobloc - Fill/Finish Packaging System

### General Overview

- Ability to sort, feed, fill, plug, stopper, crimp, cap and/or accumulate in a compact footprint
- Optional mounted HEPA filtration hood
- Runs plastic & glass bottles, vials, microtubes, and pre-capped microtubes
- Servo-driven technology offers improved control and reliability for stopper/tip placement, cap torque, and indexing systems
- Optimally designed for cGMP/FDA required environments
- User-friendly, menu driven HMI touchscreen operator interface



Unique Performance. Undeniable Quality. Unrivaled Support.  
Go Further, Do More with FILAMATIC.

# Mini-Monobloc - Fill/Finish Packaging System

866.258.1914  
info@filamatic.com  
www.filamatic.com



### Technical Features

- Approximate dimensions: 24" x 48" x 54"
- Fill accuracy: + / - 0.5%
- Fill volume range: microliters to 120ml
- Choice of filling system: positive displacement, peristaltic, or micro-dose rotary piston
- Designed with casters for portability

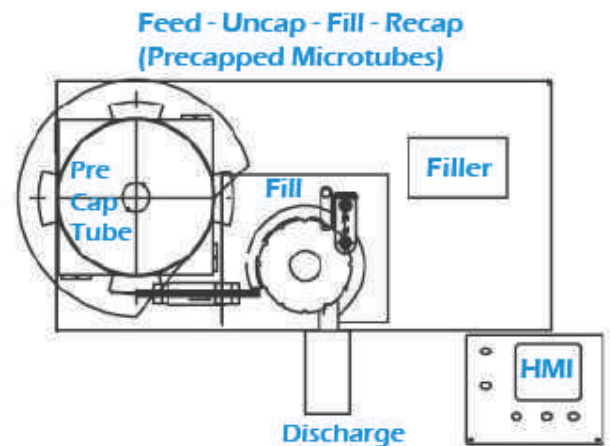
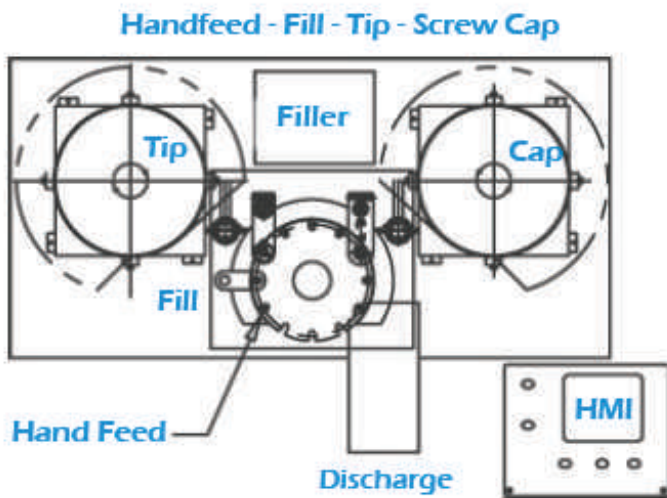
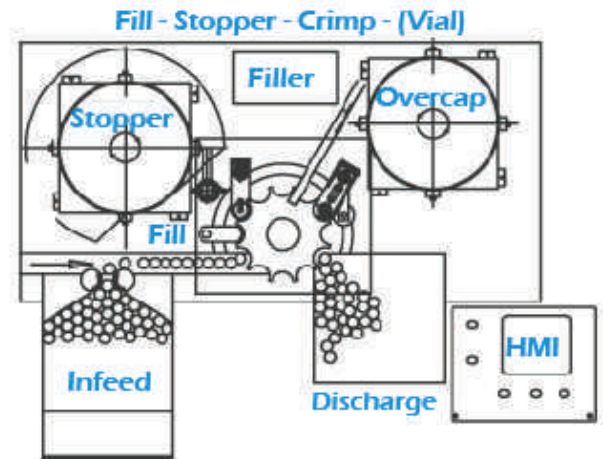
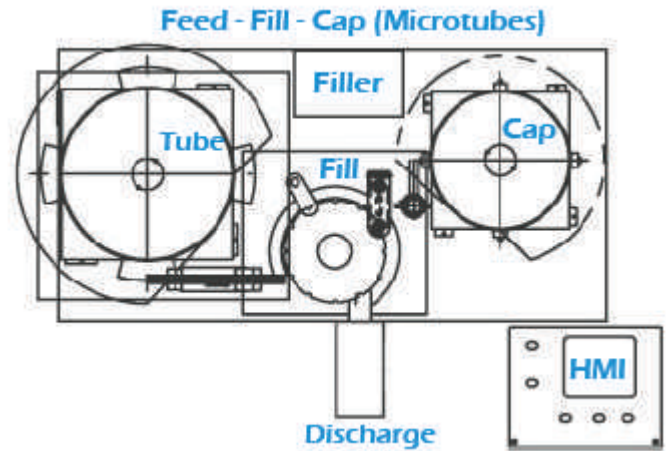

FILAMATIC

4119 Fordleigh Road • Baltimore, MD 21215  
 866.258.1914 • info@filamatic.com • www.filamatic.com