

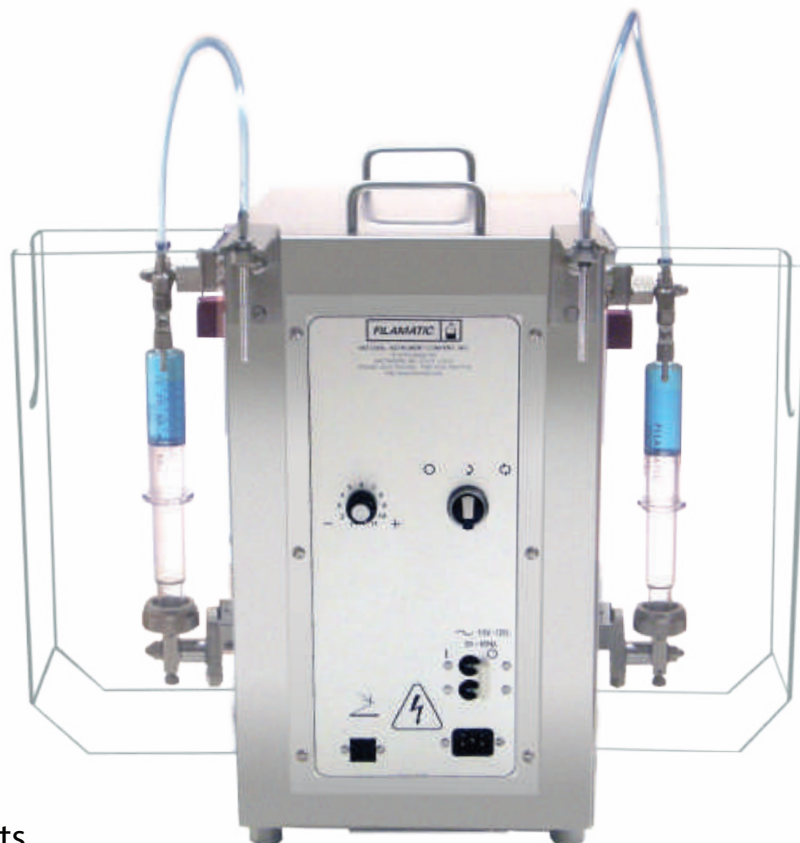

DAB Series - Semi-Automatic Benchtops

General Overview

- Multiple pumps with fill volume ranging up to 260ml
- Easy to set-up, operate, clean, and quick recipe changeovers
- Accommodates free-flowing, semi-viscous, viscous, molten products, and products with particulates
- Durable stainless steel structure
- Ability to mix and match pumps and nozzles for optimal versatility and flexibility
- CE Mark and explosion resistant available for hazardous environments
- Ability to scale and turn into a Turnkey Fill-Cap-Label System



Unique Performance. Undeniable Quality. Unrivaled Support.
Go Further, Do More with FILAMATIC.

DAB Series Benchtops Semi-Automatic Models

866.258.1914
info@filamatic.com
www.filamatic.com



Technical Features

- Fill accuracy + / - 0.5%
- Ideal for dispensing separate liquids into one container
- Product may be supplied from floor level, overhead, or a pressurized source depending on metering system selected
- Ability to fill a wide range of containers such as plastic, glass bottles, pouches, syringes, and test tubes
- 100% USA Made: designed, engineered, and manufactured

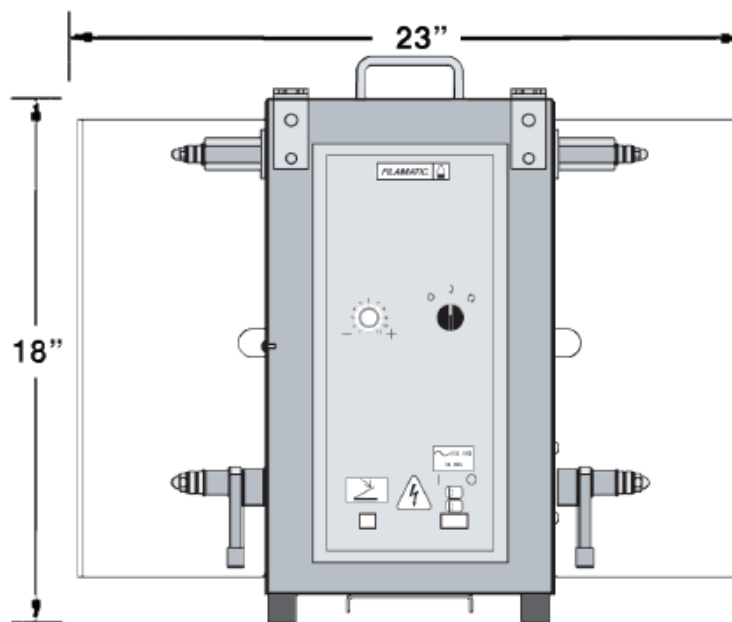

Model	Fill Stations	Volts	RPM	Fill Size
DAB-5	2	110V or 220V	Up to 35	1ml to 130ml
DAB-8	2	110V or 220V	Up to 16	1ml to 260ml
DAB-A-8	2	20-25 scfm	Up to 16	1ml to 260ml

FILAMATIC

4119 Fordleigh Road • Baltimore, MD 21215
 866.258.1914 • info@filamatic.com • www.filamatic.com