

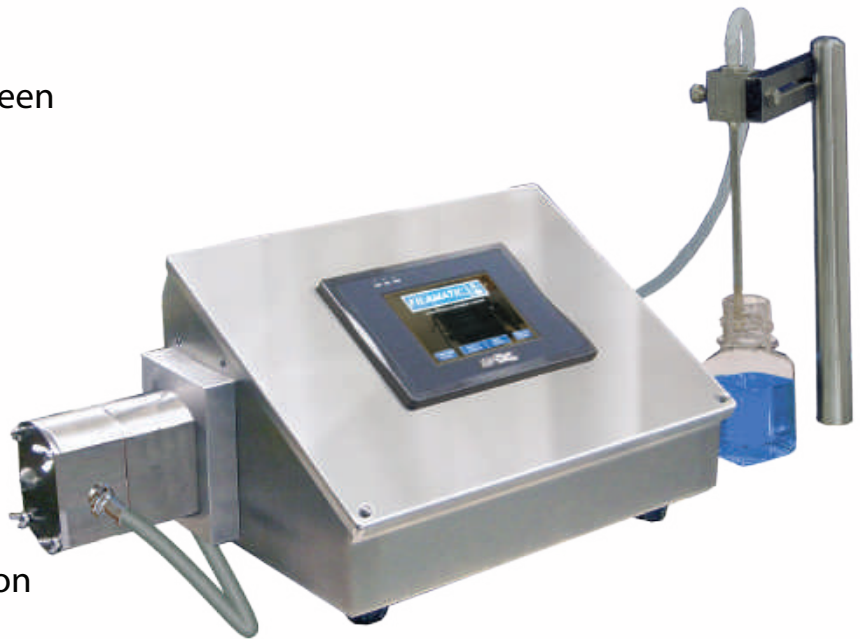

## AdaptaFil - Semi-Automatic Benchtops

### General Overview

- User-friendly, easy (HMI) touchscreen
- Servo-motor driven technology
- Digitally controlled, no manual adjustments
- Recipe recall that allows you to create, save, and copy +100 recipes by name
- Advanced fill-weight compensation
- Adjustable batch counting control
- Clean room build and design
- Solutions for OEM integration
- Metering pumps available: piston, lobe, gear, and peristaltic (4 Machines in 1)



Unique Performance. Undeniable Quality. Unrivaled Support.  
Go Further, Do More with FILAMATIC.

# AdaptaFil Benchtop Semi-Automatic Models

866.258.1914  
info@filamatic.com  
www.filamatic.com



### Technical Features

- Quick and easy changeovers
- 110 V power
- Stainless steel design and build
- Fill accuracy +/- 0.5% depending upon metering pump selected
- Modular design with built-in expansion capability

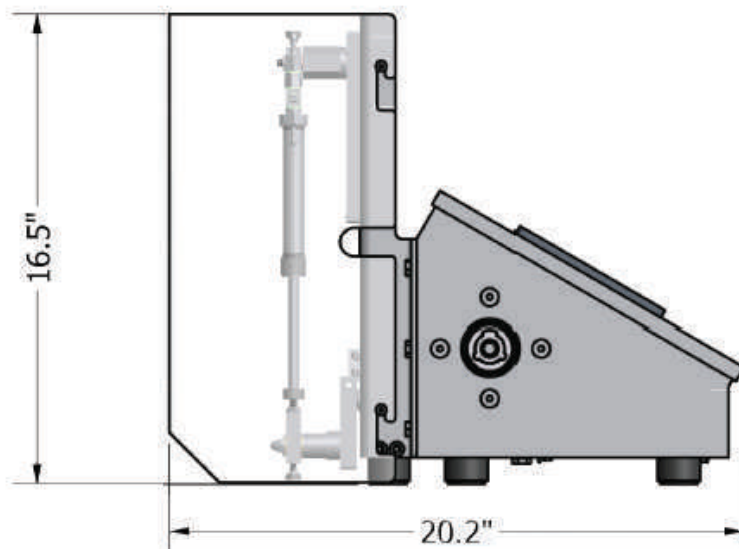

Metering Systems	Fill Volume Range/Rates		Product Description
Peristaltic	Up to 1.16 gallons/min	4.37 liters/min	Free Flowing
Gear	Up to 3.5 gallons/min	13.25 liters/min	Free Flowing Semi-Viscous Viscous Particulates
Lobe	Up to 4 gallons/min	15.4 liters/min	Free Flowing Semi-Viscous Viscous Particulates
Piston	.3ml to 260ml per stroke	35 stroke/min	Free Flowing Semi-Viscous