

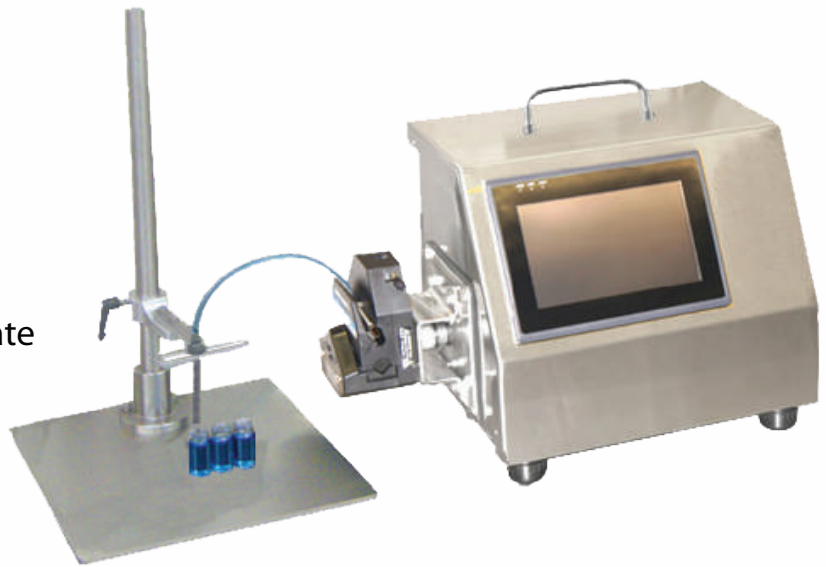

SmartFIL Benchtop

General Overview

- Easy-to-Use HMI touchscreen
- Unmatched filling flexibility
- Self-priming, and reversible for drip free filling
- Recipe recall that allows you to create, save, and copy 100+ recipes
- Stackable peristaltic pumps for increased production
- Advanced fill weight compensation
- Easy setup, low maintenance, and quick changeovers



Unique Performance. Undeniable Quality. Unrivaled Support.
Go Further, Do More with Filamatic.

SmartFIL Benchtop

866.258.1914
info@filamatic.com
www.filamatic.com



Technical Features

- Tool-less changeover
- 110 V power
- Stainless steel cabinet
- Quick clean-up
- Fill Accuracy +/- 0.5% depending upon metering pump selected
- Modular design with built-in expansion capability

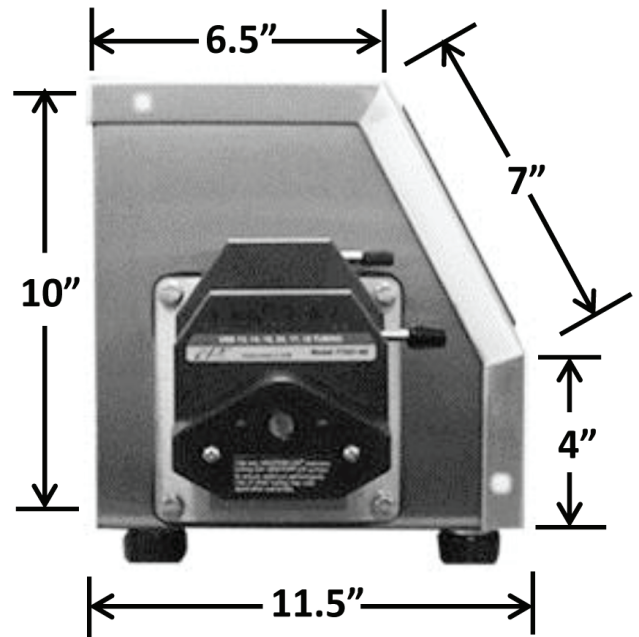

Peristaltic	Fill Volume Range/Rates	Product Description
MasterFlex	.08 to 480ml Per Minute	Free Flowing Semi-Viscous
Watson Marlow	4.37 Liters Per Minute	Free Flowing Semi-Viscous
Flexicon	4.50 Liters Per Minute	Free Flowing Semi-Viscous