

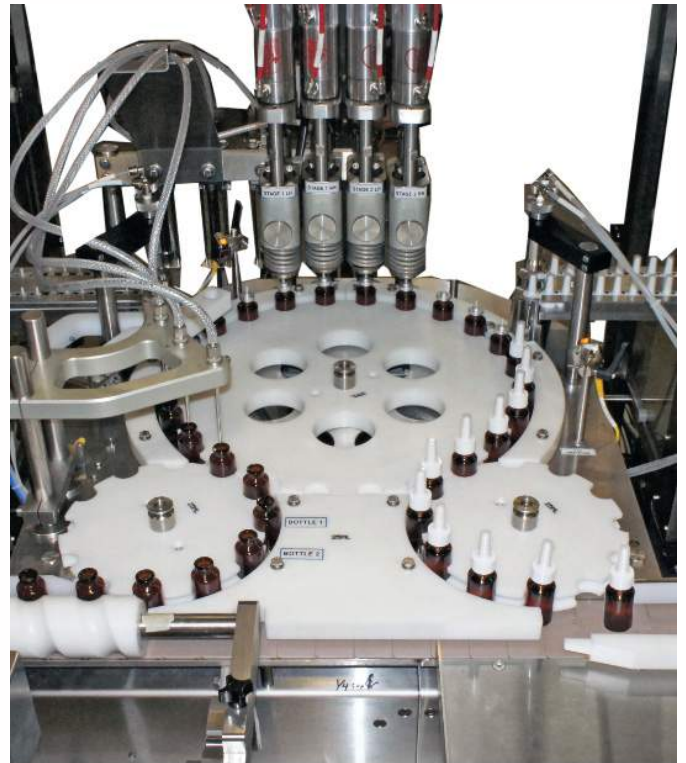

Monobloc XT - High-Speed System

General Overview

- High flexibility
- Robust, ergonomic design and minimum maintenance
- Fast, straightforward format changeovers
- Easy adaptation to new packaging
- Bottom-up filling, locate filling & static filling
- Recipe driven changeover
- Highest precision/most advanced pumps driven by individual servo motors



Unique Performance. Undeniable Quality. Unrivaled Support.
Go Further, Do More with Filamatic.

Monobloc XT
High-Speed System

866.258.1914
info@filamatic.com
www.filamatic.com



Technical Features

- Approximate dimensions: 24" x 48" x 54"
- Fill accuracy: + / - 0.5% or better
- Fill volume range: microliters to 120ml
- Choice of filling system: positive displacement, peristaltic, or micro-dose rotary piston
- Designed with casters for portability

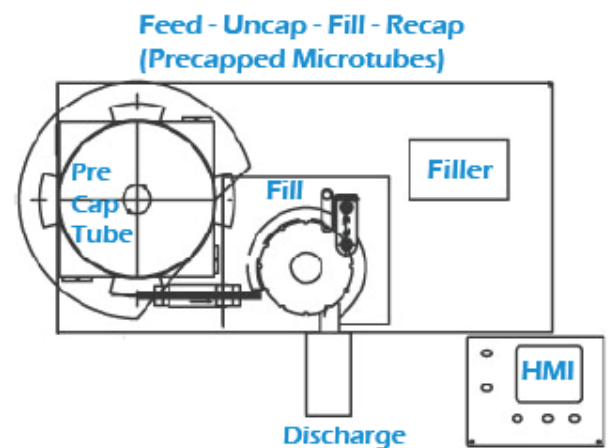
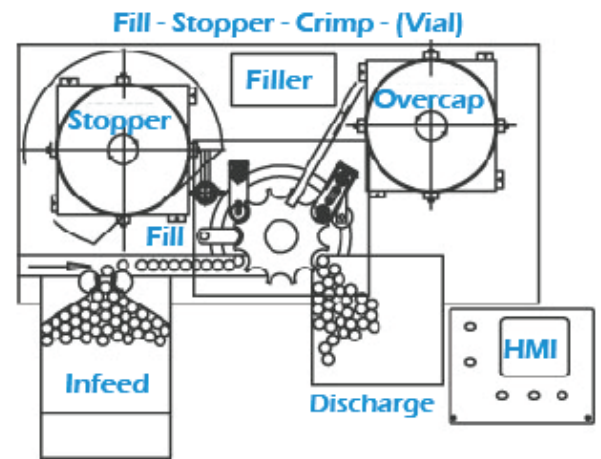
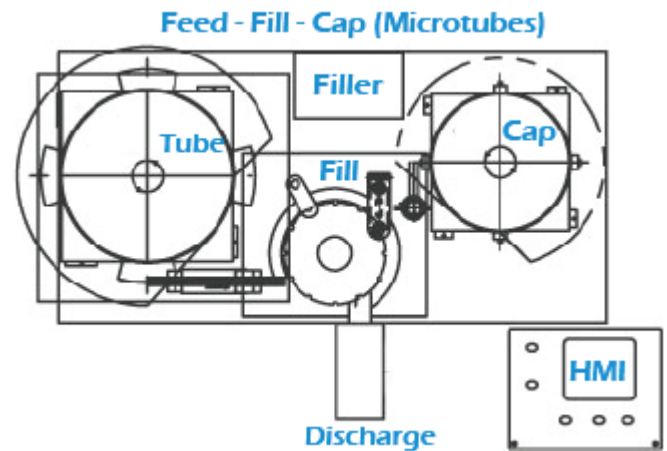
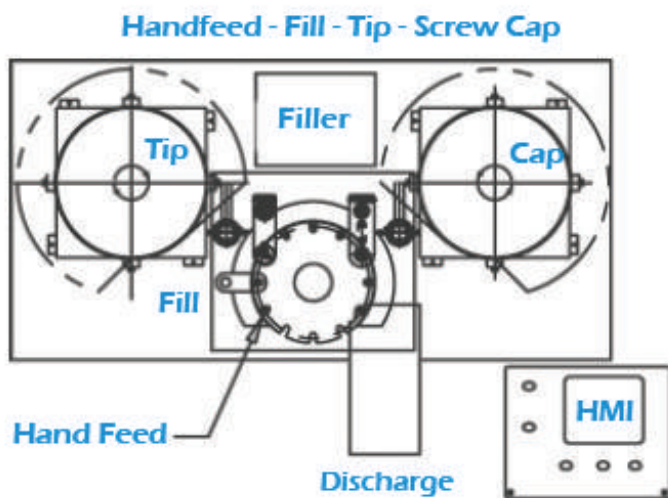

Filamatic

4119 Fordleigh Road • Baltimore, MD 21215

866.258.1914 • info@filamatic.com • www.filamatic.com



Technical Features

- Approximate dimensions: 24" x 48" x 54"
- Fill accuracy: + / - 0.5% or better
- Fill volume range: microliters to 120ml
- Choice of filling system: positive displacement, peristaltic, or micro-dose rotary piston
- Designed with casters for portability

Feed - Fill - Cap (Microtubes)

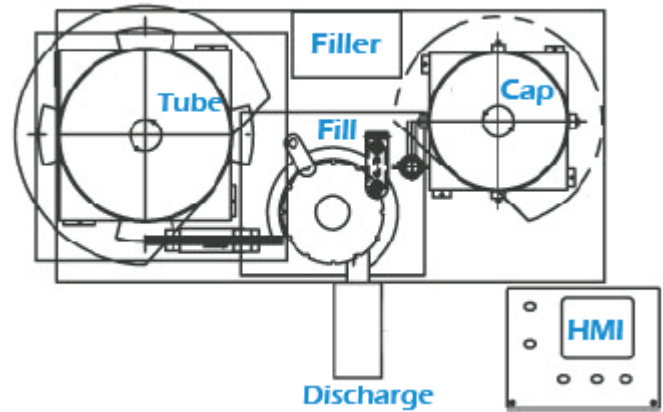

Fill - Stopper - Crimp - (Vial)

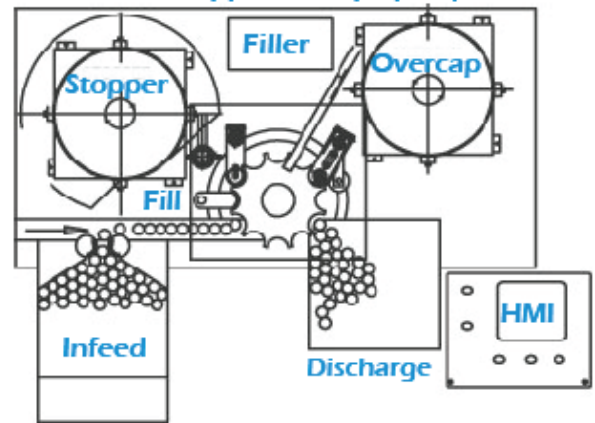

Handfeed - Fill - Tip - Screw Cap

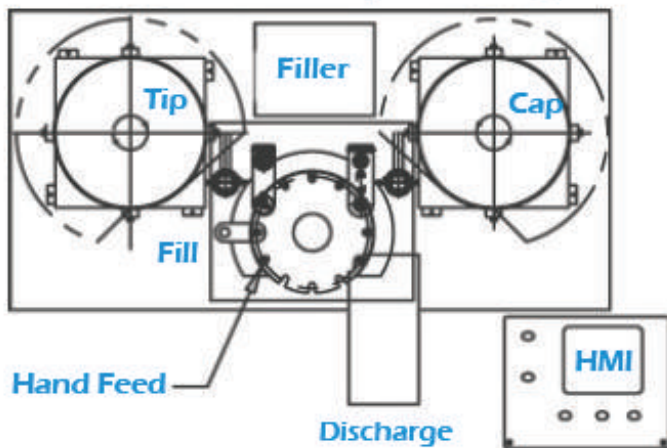

Feed - Uncap - Fill - Recap (Precapped Microtubes)

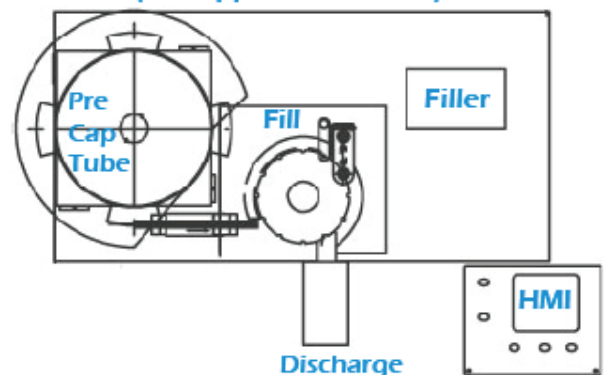

Filamatic

4119 Fordleigh Road • Baltimore, MD 21215

866.258.1914 • info@filamatic.com • www.filamatic.com