



Monobloc - Fill & Finish System

General Overview

- Ability to sort, feed, fill, plug, stopper crimp, cap, label, and/or accumulate in a compact footprint
- User-friendly, menu driven HMI touchscreen operator interface
- Quick and easy tool-less changeovers
- Standard laminar airflow design for cleanroom
- Servo-motor driven technology
- Optional HEPA filtration system available
- Recipe driven changeovers
- Optional remote access



Unique Performance. Undeniable Quality. Unrivaled Power.
Go Further, Do More with Filamatic.

Monobloc - Fill & Finish Fully-Automated System

866.258.1914
info@filamatic.com
www.filamatic.com



Technical Features

- Handles free-flowing to viscous products
- Fill accuracy: +/- 0.5% or better
- Fill volume range: 0.5ml to 500ml
- Choice of metering systems: Positive displacement, Peristaltic, or Micro-Dose Rotary Piston
- Optional Net Weigh capability
- Optimally designed for cGMP/FDA environments
- Optional mounted HEPA filtration hood
- Optional down stream equipment: print, labeling and other ancillary solutions

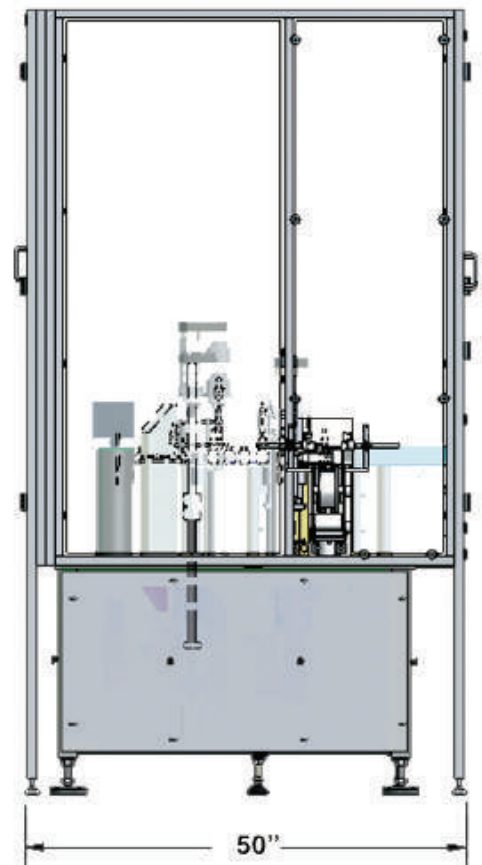
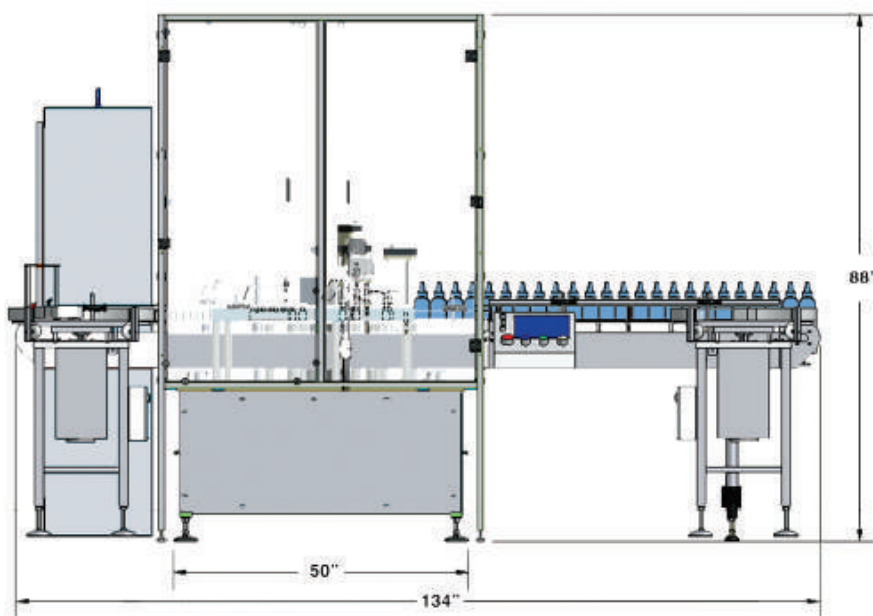

FILAMATIC

4119 Fordleigh Road • Baltimore, MD 21215
866.258.1914 • info@filamatic.com • www.filamatic.com