



EconoFIL Automatic Filler

General Overview

- Modular design automates DAB-5, DAB-8, and/or AdaptaFIL benchtop models
- Capable of 50+ bottles per minute (bpm)
- Programmable Controller
- Conveyor lengths available in 8, 10, 12, and 16 feet
- Multiple container indexing options
- Stainless steel construction
- Horizontal bottle centering system
- +/- 1% or better fill accuracy



Unique Performance. Undeniable Quality. Unrivaled Support.
Go Further, Do More with Filamatic.

***EconoFIL Automatic
Filler***

866.258.1914
info@filamatic.com
www.filamatic.com



Technical Features

- Product may be supplied from floor level reservoir, overhead supply, or a pressurized source
- Optional air motor drive available for hazardous environments
- Optional peristaltic pump
- Fill accuracy +/- 0.5% or better
- A Range of FILAMATIC piston pump sizes and models available
- Optional multi-stroke system extends range beyond 260mL
- Fill rate: up to 50 cpm with 2 filling heads
- 8, 10, and 12 foot conveyer options

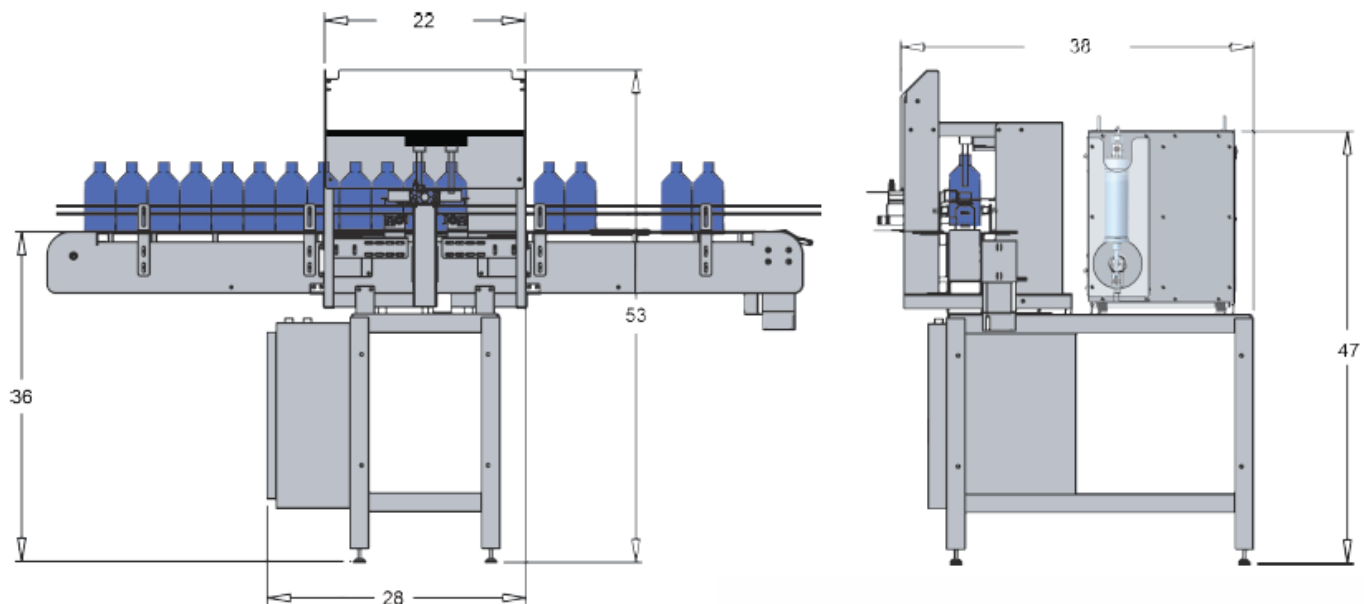

Filamatic

4119 Fordleigh Road • Baltimore, MD 21215
866.258.1914 • info@filamatic.com • www.filamatic.com