



DFS System - Piston Pump

General Overview

- Three frame sizes to handle up to 20 piston pumps
- Fill rates up to 300 CPM
- Dockable trolley system reduces changeover to +/- 5 minutes
- Tool-less adjustments
- Bottom-up, locate, and static fill modes for nozzle position
- Handles low to high viscosities
- 316/316L stainless steel product contact path
- Fill accuracies to +/- 0.5% or better
- Indexing and continuous motion filling



Unique Performance. Undeniable Quality. Unrivaled Support.
Go Further, Do More with Filamatic.

***DFS System
Piston Pump***

866.258.1914
info@filamatic.com
www.filamatic.com



Technical Features

- Interlocked safety enclosure constructed of lexan and stainless steel
- Recipe driven, servo controlled system
- Weight compensation
- Comprehensive setup, usage, drawings, and validation documentation
- Fallen bottle, infeed bottle supply, discharge bottle back-up sensors on the container handling system
- Optional hazardous environment design available
- Optional individual servos for each piston

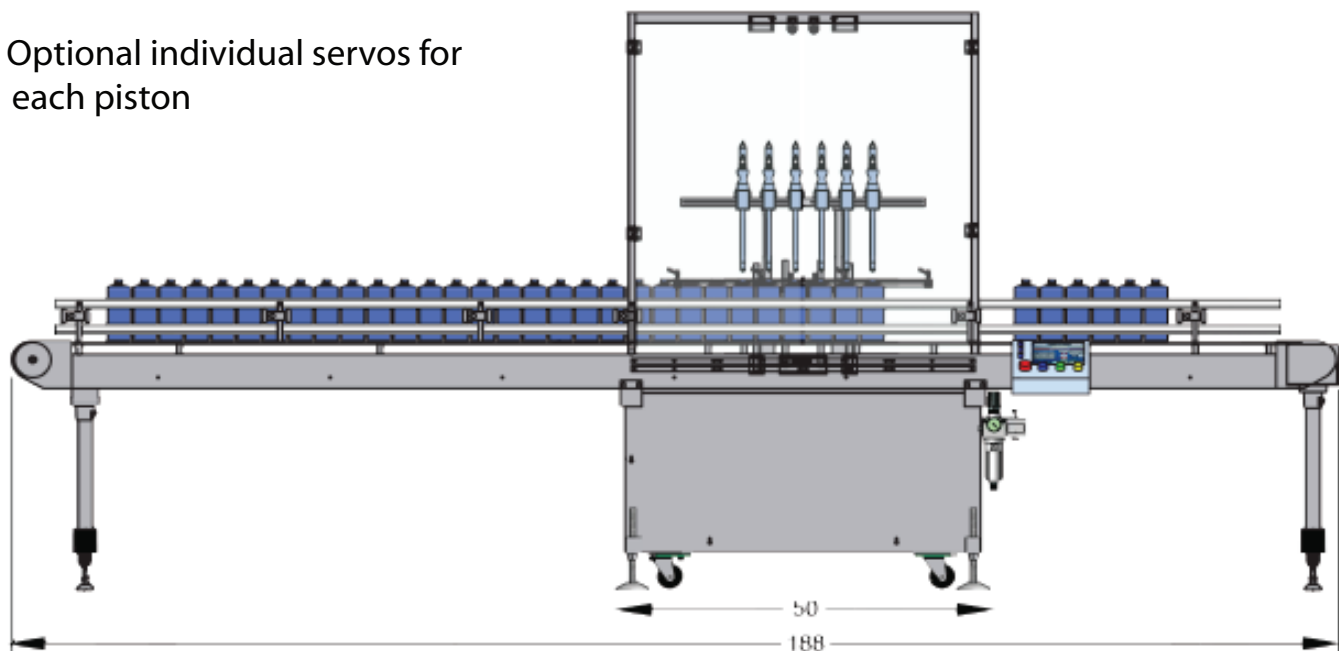
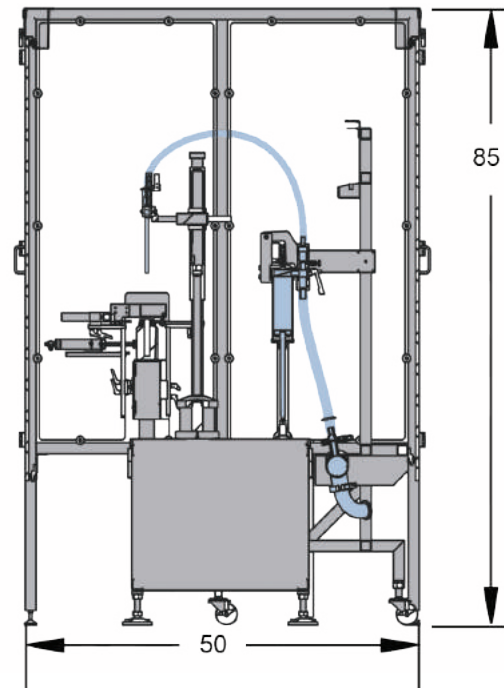

Filamatic

4119 Fordleigh Road • Baltimore, MD 21215
866.258.1914 • info@filamatic.com • www.filamatic.com