



DFS System - Flow Meter

General Overview

- Three frame sizes to handle up to 14 flow meters
- Dockable trolley system reduces changeover to +/- 5 minutes
- Tool-Less adjustments
- Indexing and continuous motion filling
- Bottom-Up, locate, and static fill modes for nozzle position
- Fill rates of 10 to 200+ CPM
- Fill accuracies to +/- 0.5% or better
- 316/316L product contact path



Unique Performance. Undeniable Quality. Unrivalled Support
Go Further, Do More with Filamatic.

***DFS System
Flow Meter***

866.258.1914
info@filamatic.com
www.filamatic.com



Technical Features

- Interlocked safety enclosure constructed of lexan and stainless steel
- Best for moderate to large fills (50ml to gallons)
- Comprehensive setup, usage, drawings, and validation documentation
- Fallen bottle, infeed bottle supply, discharge bottle back-up sensors on the container handling system
- Clean In Place (CIP) or optional remote CIP system
- Recipe driven system

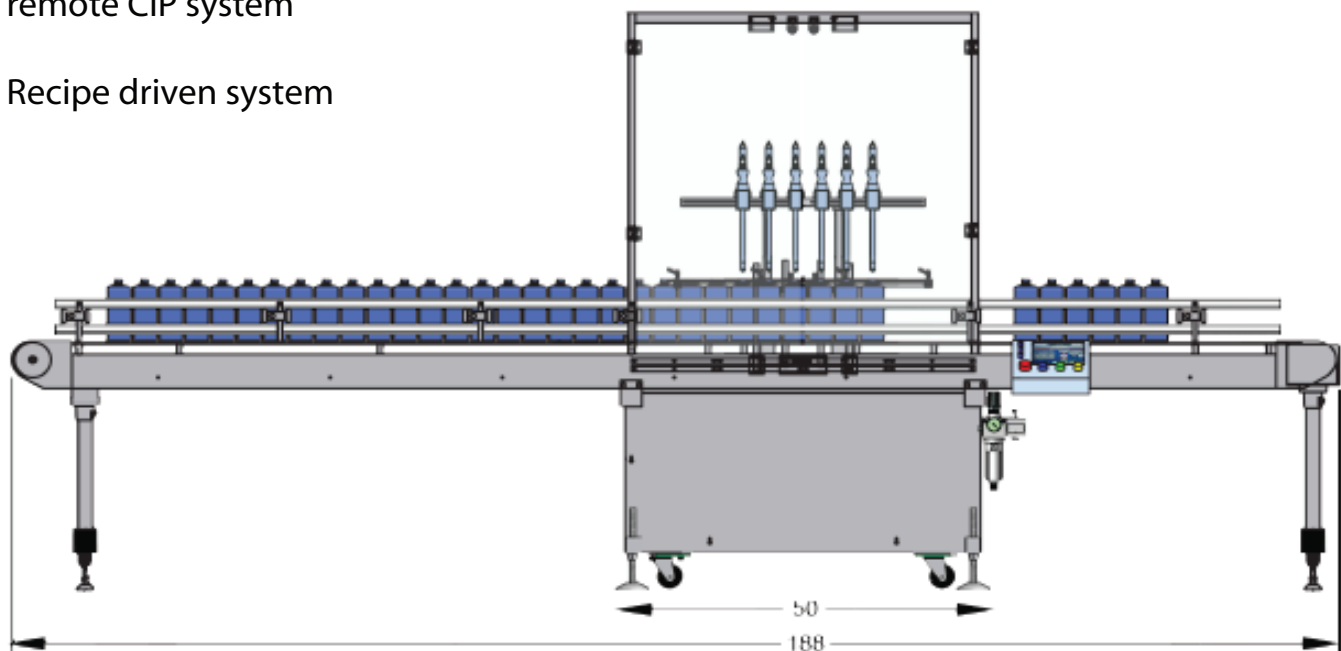
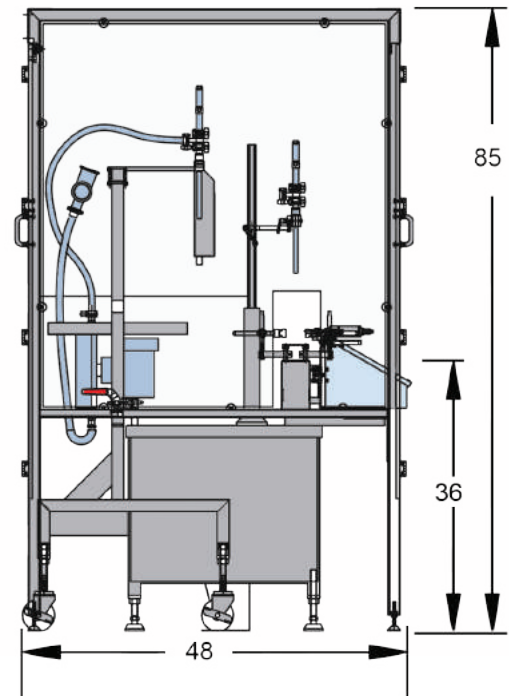

Filamatic

4119 Fordleigh Road • Baltimore, MD 21215
866.258.1914 • info@filamatic.com • www.filamatic.com