

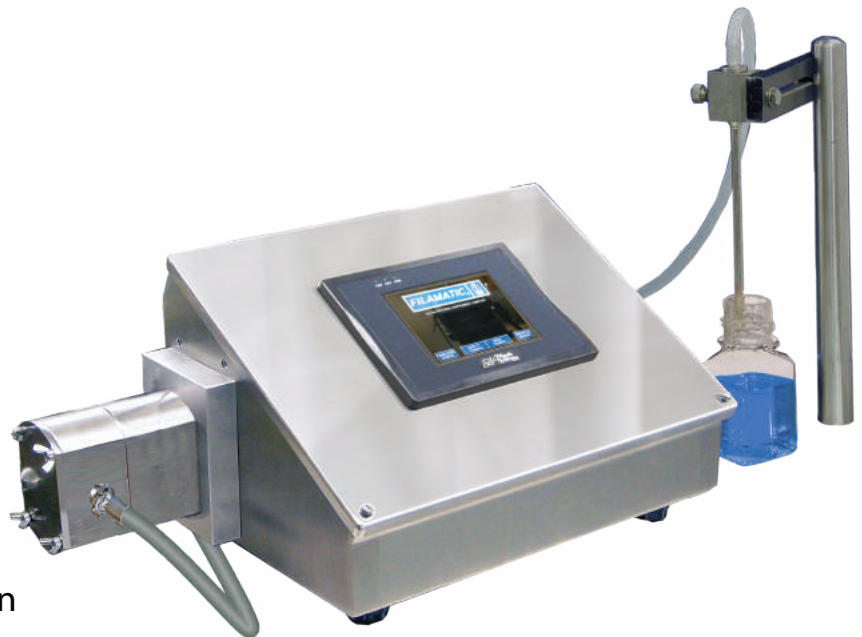

AdaptaFil Semi-Automatic Benchtop Series

General Overview

- User-friendly (HMI) touchscreen
- Servo-motor driven technology
- Digitally controlled with no manual adjustments
- Recipe recall that allows you to create, save, and copy 100+ recipes by name
- Advanced fill-weight compensation
- Adjustable batch counting control
- Clean room build and design
- Metering pumps available: piston, lobe, gear, and peristaltic (4 machines in 1)



Unique Performance. Undeniable Quality. Unrivaled Support.
Go Further, Do More with Filamatic.

***AdaptaFil Semi-Automatic
Benchtop Series***

866.258.1914
info@filamatic.com
www.filamatic.com



Technical Features

- Quick and easy changeovers
- 110 V power
- Stainless steel design and build
- Fill accuracy +/- 0.5% depending upon metering pump selected
- Modular design with built-in expansion capability

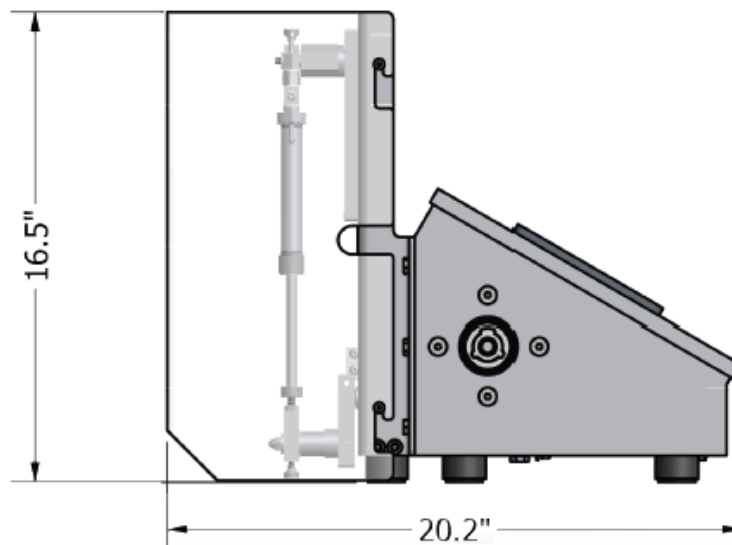

Metering Systems	Fill Volume Range/Rates		Product Description
Peristaltic	Up to 1.16 gallons/min	4.37 liters/min	Free Flowing
Gear	Up to 3.5 gallons/min	13.25 liters/min	Free Flowing Semi-Viscous Viscous Particulates
Lobe	Up to 4 gallons/min	15.4 liters/min	Free Flowing Semi-Viscous Viscous Particulates
Piston	.3ml to 260ml per stroke	35 stroke/min	Free Flowing Semi-Viscous

Filamatic

4119 Fordleigh Road • Baltimore, MD 21215
866.258.1914 • info@filamatic.com • www.filamatic.com