



AB Semi-Automatic - Benchtop Series

General Overview

- Capable of dispensing wide range of fill volumes
- Models available for use in filling hazardous environments
- Compact design and stainless steel construction
- Simple to set-up, operate, clean and changeover
- 110v operation



Unique Performance. Undeniable Quality. Unrivaled Support.
Go Further, Do More with Filamatic.

***AB Semi-Automatic
Benchtop Series***

866.258.1914
info@filamatic.com
www.filamatic.com



Technical Features

- Fill accuracy + / - 0.5%
- Excellent system for small to medium batch runs - great liquid filler for companies tired of manually filling containers
- Product may be supplied from floor level, overhead, or a pressurized source depending on pump system
- Ability to fill a wide-range of containers such as plastic, glass bottles and large-containers
- Serious workhorse, incredibly durable and pinpoint precision liquid filler

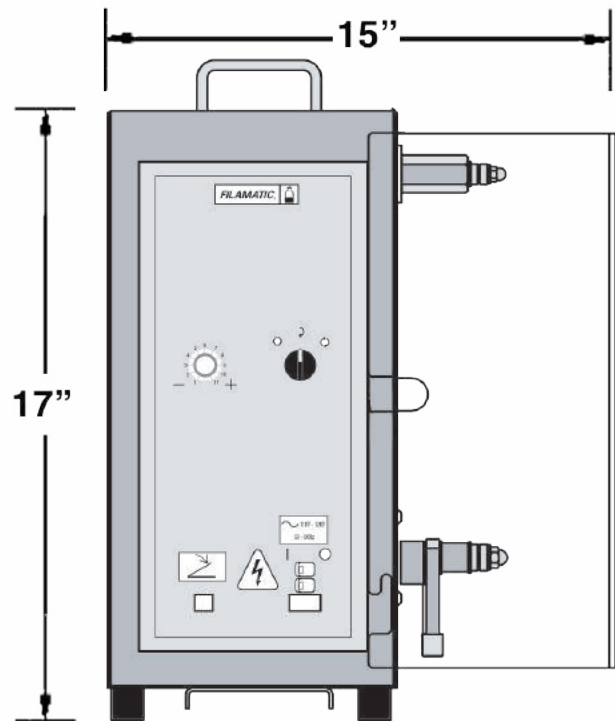

Model	Fill Stations	Volts	RPM	Fill Size
AB	1	110V or 220V	84	.05ml to 50ml
AB-5	1	110V or 220V	35	1ml to 130ml
AB-8	1	110V or 220V	30	3ml to 260ml
AB-A-8	1	30-40 CFM	30	3ml to 260ml

FILAMATIC

4119 Fordleigh Road • Baltimore, MD 21215
 866.258.1914 • info@filamatic.com • www.filamatic.com