

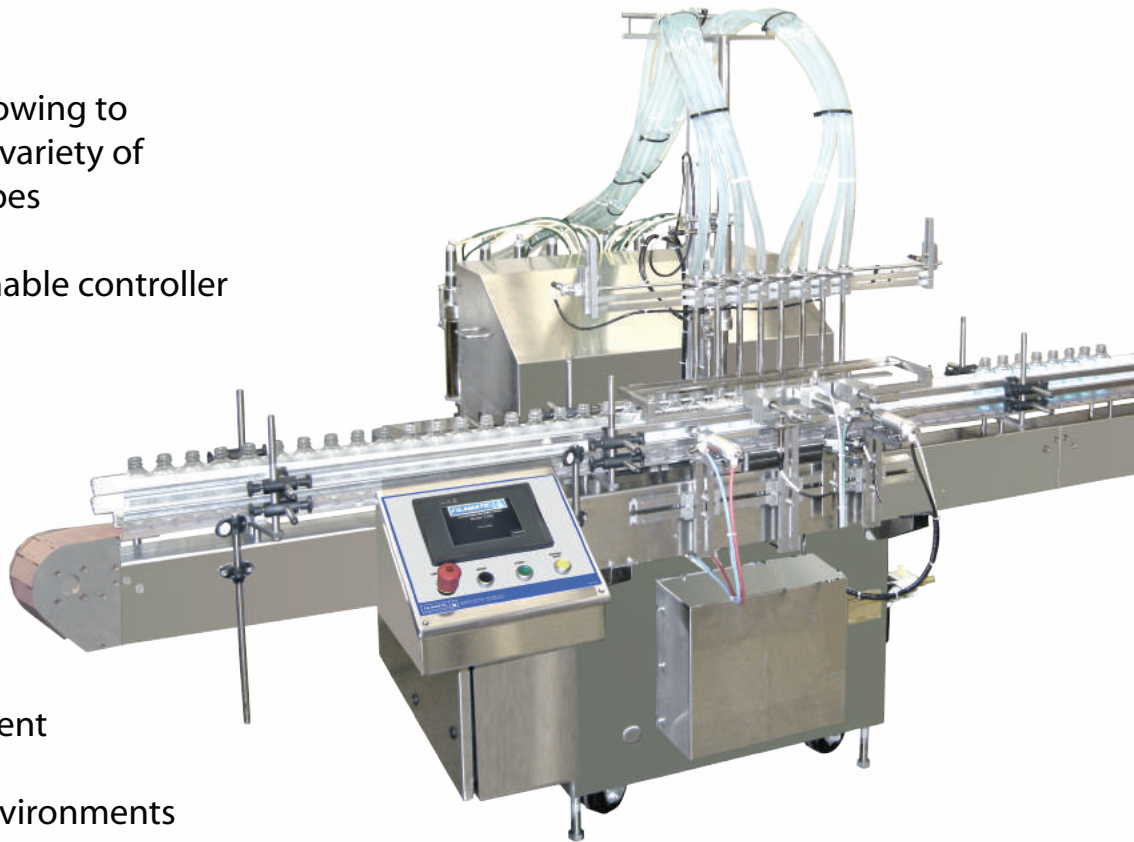

Automatic V-Series

General Overview

- Accommodates free-flowing to viscous Products with a variety of container sizes and shapes
- Easy-to-Use programmable controller
- Bottom-Up, locate, and static fill modes for nozzle position control
- Expandable Design
- Fast Changeovers
- Quick volume adjustment
- Optional hazardous environments model available
- Optional HMI touchscreen and servo motor main drive
- Sanitary closed top conveyor



Unique Performance. Undeniable Quality. Unrivaled Support.
Go Further, Do More with Filamatic.

**Automatic
V-Series**

866.258.1914
info@filamatic.com
www.filamatic.com



Technical Features

- Easy to operate, powerful output
- Free standing unit with stainless steel frame and design
- Built-in leveling equipment (jack screws)
- Fill Accuracy + / - 0.5%
- Rates: V-300 up to 200 cpm and V-480 up to 300 cpm

Type of Filling Unit	Number of Filling Units	
	V-300	V-480
FUS (XL) 80 FKS (XL) 80	12	22
FUS (XL) 140 FKS (XL) 140	12	16
FUS (XL) 280 FKS (XL) 280	8	16
FUS (XL) 560 FKS (XL) 560	8	14
FUS (XL) 1100 FKS (XL) 1100	6	10
FSV/XL	8	14

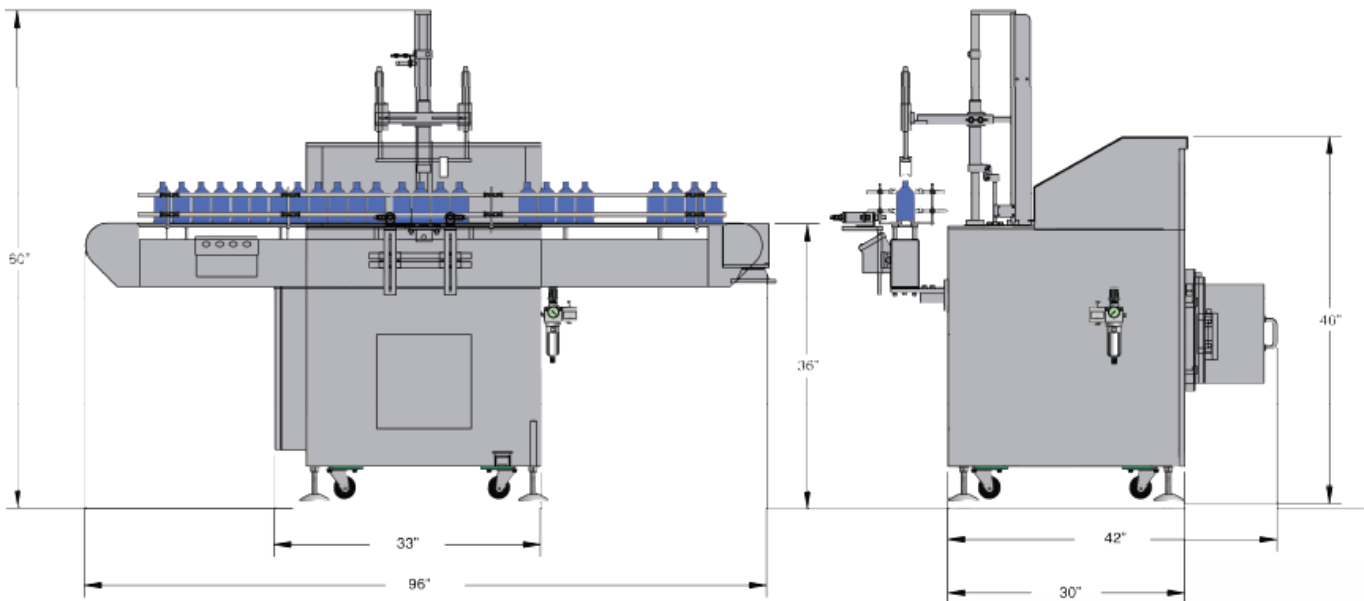

Filamatic

4119 Fordleigh Road • Baltimore, MD 21215
866.258.1914 • info@filamatic.com • www.filamatic.com