



## Automatic Synchronat

### General Overview

- Fill accuracy of  $\pm$ /- 1% or better
- Horizontal bottle centering system
- Scalable filling stations
- Programmable Controller
- Fallen bottle sensor at infeed
- Dispenses free flowing to high viscosity liquids
- Design allows you to expand from 2 to 20 nozzles as production demands increase
- Optional multi-stroke system extends range beyond one Liter



Unique Performance. Undeniable Quality. Unrivaled Support.  
Go Further, Do More with Filamatic.

***Automatic  
Synchronat***

866.258.1914  
info@filamatic.com  
www.filamatic.com



## Technical Features

- Product may be supplied from floor level reservoir, overhead supply, or a pressurized source

- Optional air motor drive available for hazardous environments

- Fill rate: up to 34 cpm with 2 filling heads and up to 200 cpm with 20 filling heads

- Optional multi-stroke system extends range beyond 1 liter

- Fill accuracy + / - .5% or better

- A range of FILAMATIC piston pump sizes and models available

Size of Filling Unit	Number of Filling Units					
	SYN-8-2	SYN-8-4 (No Drive Bars)	SYN-8-4 (With Drive Bars)	SYN-32-2	SYN-32-4 (No Drive Bars)	SYN-32-4 (With Drive Bars)
1 to 10 ml	2	4	10	2	4	4
3 to 130 ml	2	4	8	2	4	20
80 ml	-	-	-	2	4	20
140 ml	-	-	-	2	4	20
260 ml	2	4	6	2	4	12
280 ml	-	-	-	2	4	12
560 ml	-	-	-	2	4	8
1100 ml	-	-	-	2	4	4

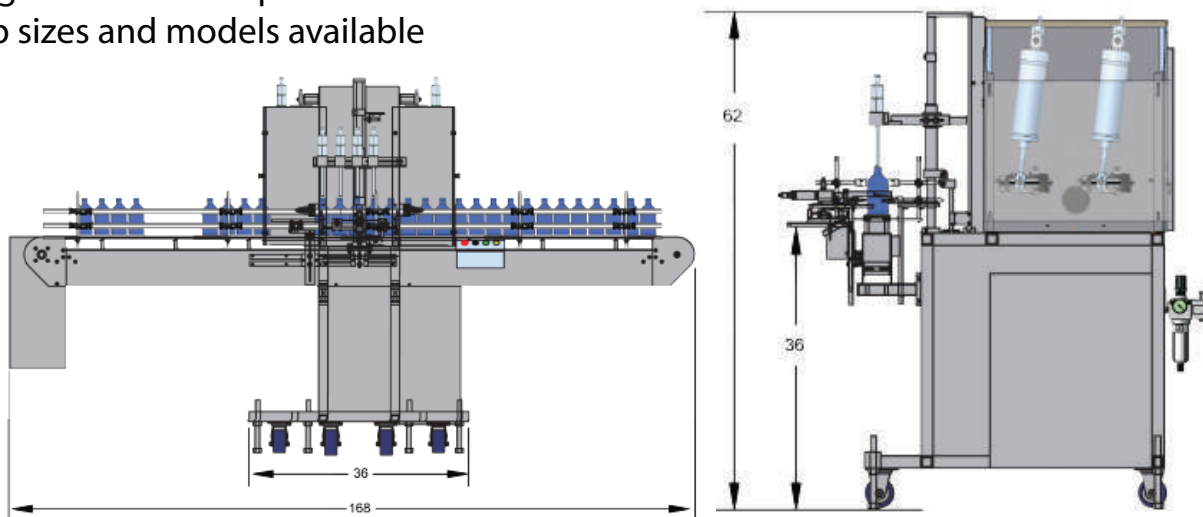

Filamatic

4119 Fordleigh Road • Baltimore, MD 21215

866.258.1914 • info@filamatic.com • www.filamatic.com