



Automatic H-CE Molten Products Hot Filler

General Overview

- Fills Liquids or Liquefied Solids up to 190 Degrees Fahrenheit
- Ideal for product fills up to 200 deg F
- Fills Molten Products (Lipstick, Lip Balm, Deodorants, Candle Wax, Ointments) with Ease and Precision
- Fills up to 350 Containers Per Minute
- 1ml to 1100ml volumes
- Product manifold allows re-circulation mode
- Surge tank or product manifold



Unique Performance. Undeniable Quality. Unrivaled Support
Go Further, Do More with Filamatic.

***Automatic H-CE Molten
Products Hot Filler***

866.258.1914
info@filamatic.com
www.filamatic.com



Technical Features

- Filling Units can be Disassembled in Minutes for Cleaning, or can be Cleaned In Place with an Optional Flush-Back System
- Optional Hazardous Environment Design Available
- Fill Ranges from 1ml to 1100ml per Stroke with a Fill Accuracy of +/- 0.5%
- Inline and Gantry Configurations
- Optional Remote Diagnostics; Mixing Nozzles
- Locate, Bottom Up, or Static Fill Modes
- Optional HMI Touchscreen
- Servo Driven Indexing or Continuous-Motion Filling
- Integrates Easily with Puck Loading/ Unloading Upstream and Downstream Components such as Conveyors, Unscramblers, Cappers, and Labeler

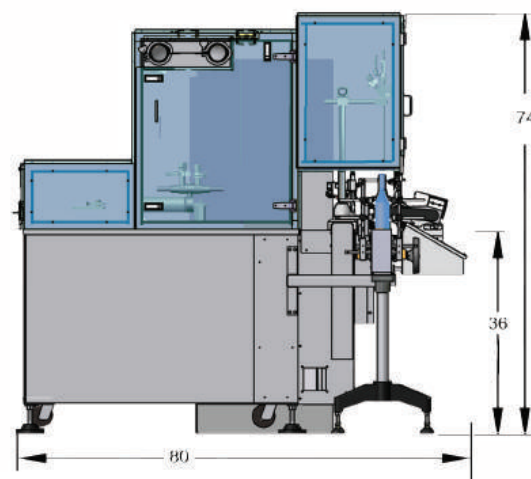
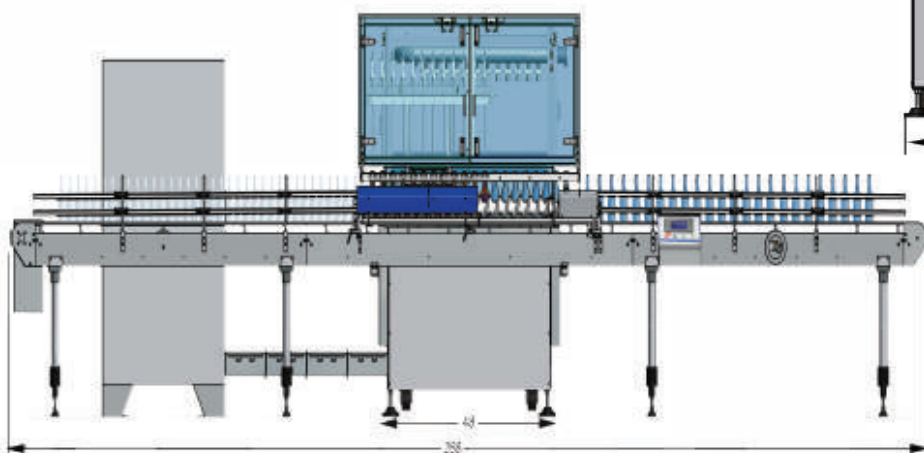

Filamatic

4119 Fordleigh Road • Baltimore, MD 21215
866.258.1914 • info@filamatic.com • www.filamatic.com