



DAB-8-4 Heavy Duty - Semi-Automatic Benchtop Series

General Overview

- Automation for OEM applications available
- Easy to Set-up, operate, clean and fast changeovers
- Accommodates free-flowing, semi-viscous, viscous, molten products, and products with particulates
- Durable stainless steel structure
- Modular design with built-in expansion capability for production changes
- Heavy-Duty base frame with diving nozzles available
- CE Mark and explosion proof design available for hazardous environments



Unique Performance. Undeniable Quality. Unrivaled Support.
Go Further, Do More with Filamatic.

***DAB-8-4 Heavy-Duty
Semi-Automatic Benchtop Series***

866.258.1914
info@filamatic.com
www.filamatic.com



Technical Features

- Fill accuracy + / - 0.5%
- Optional diving nozzle mechanism available
- Product may be supplied from floor level, overhead, or a pressurized source depending on piston pump system selected
- Ability to fill a wide range of containers such as plastic and glass bottles, pouches, syringes, and test tubes
- Manufactured in the USA

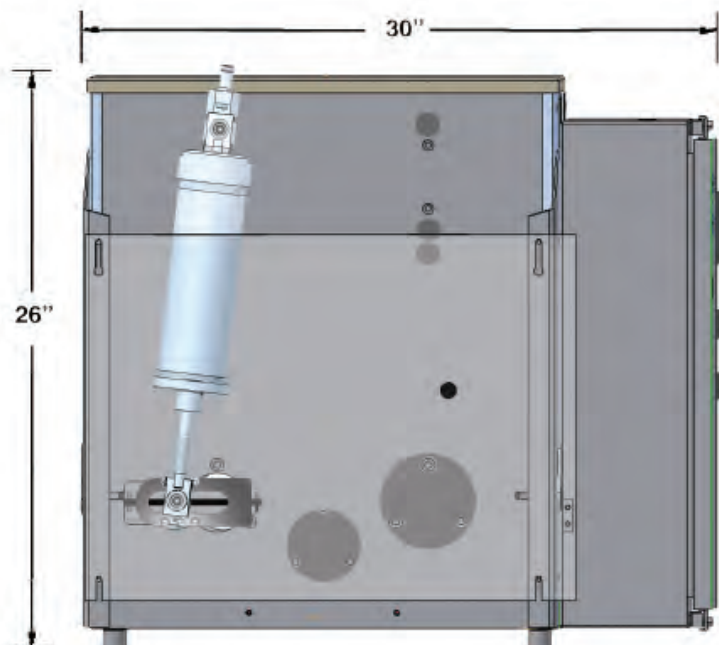

Model	Fill Stations	Volts	RPM	Fill Size
DAB-32-2	2	220V	Up to 24	1ml to 1100ml
DAB-32-4	2	220V	Up to 24	1ml to 1100ml
DAB-A-32-2	2	30-40 scfm	Up to 24	1ml to 1100ml

FILAMATIC

4119 Fordleigh Road • Baltimore, MD 21215
866.258.1914 • info@filamatic.com • www.filamatic.com