

Filamatic

Your Specialist in Liquid Filling

Filamatic, a division of National Instrument, LLC, has been serving the pharmaceutical, biotech, healthcare, contract packaging, cosmetic, chemical specialty and food industries since 1950. We provide a wide range of equipment that can be customized to suit your unique application and budget.

We meet the ever changing demands of our customers by providing high performance, reliable liquid filling systems that deliver value, accuracy, faster changeover, and low total cost of ownership year after year. Today as always, the heart of our business lies in the strong and lasting relationships we enjoy with our customers.



Specialists in Liquid Filling Systems

4119 Fordleigh Road
Baltimore, Maryland 21215 USA
Phone 866-258-1914 or 410-764-0900
sales@filamatic.com
www.filamatic.com

DFS Digifil™ Filling Systems

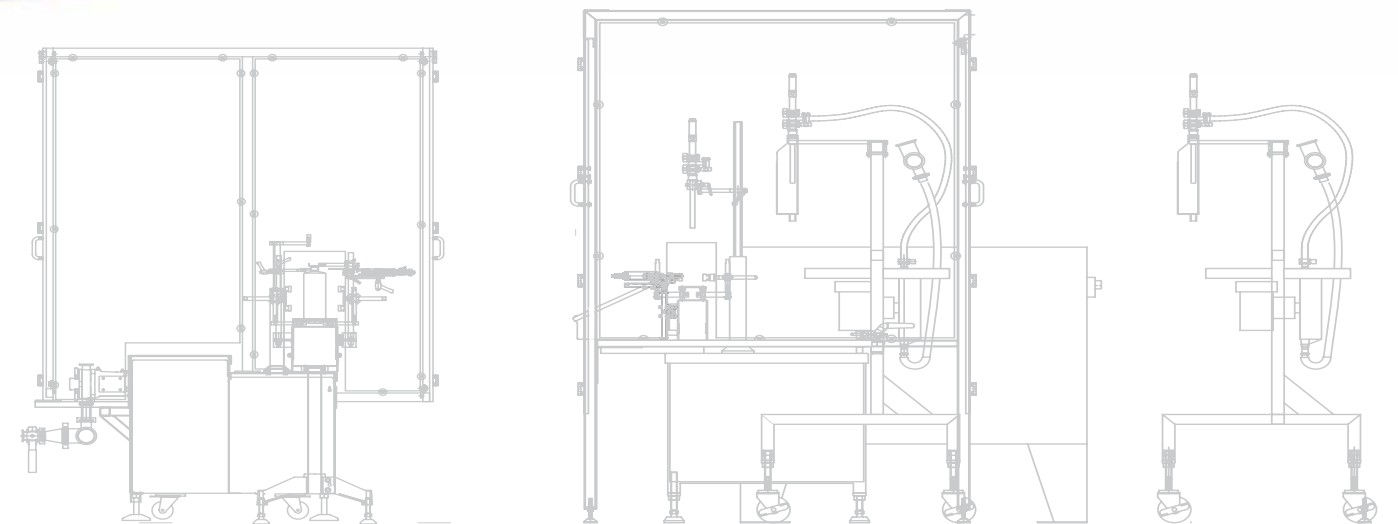

Digifil™ Inline Filling Systems

Servo-Driven, Quick and Clean Changeover

The DFS, or Digifil™, Inline Filling Systems offer the widest range of metering systems, accommodating a variety of filling applications. The Servo-Driven filling feature allows the operator to adjust the fill volume via touchscreen located on the operator interface, and comes standard with recipe recall where you can create, copy, and recall 100+ recipes. Three different frame sizes are available with the ability to handle up to 12 Filling Pumps for fill rates of 10 to 200 containers per minute.







The DFS Filling Systems can be customized depending on your liquid filling needs and application. Dockable and Non-Dockable options are available, where Dockable provides you with a removable trolley that will allow quick and clean changeovers in little as five minutes. This allows production to continue while the trolley is being cleaned or sterilized. Optional Clean-In-Place (CIP) or Clean-Out-Of-Place technology is also available.



Widest Range of Metering Systems

Multiple Pump Options Available

The DFS is unique for its ability to accommodate a wide variety of metering systems:

-  **Piston Pump** - Ideal for filling low to viscous products of 1 Liter or less. Self-priming, these pumps provide accurate fills and are widely used in the pharmaceutical industry.
-  **Lobe Pump** - Best suited for fill volumes from 50mL to 20L. Requires CIP or Remote CIP for cleaning.
-  **Peristaltic Pump** - Ideal for applications that require no metallic contact. Complete disposal of the fluid pathway allows for quick clean-up. Best used for 1mL to 1100mL fill volume ranges. These provide great accuracy with simple setup and operation.
-  **Flow Meter** - Best for applications requiring a wide range of fill volumes. They allow for fluid metering without moving parts and allows for easy CIP cleaning.
-  **Rotary Gear** - Tool-less disassembly allows for expanded cleaning options (CIP, Remote CIP, COP) and similar to the Lobe, best suited for fill volume ranging from 50mL to 20L.
-  **Rotary Piston Pump** - When precise fill accuracy is required for small volume fills (up to 10mL), the Rotary Piston is the best selection. Several pump sizes are made from a variety of materials yield compatibility with a wide range of products.

Built To Order, Built To Last



DFS Non-Dockable Filling Machine

Flexible Design, Wide Range of Filamatic Piston Pump Sizes, Product Viscosities, and Speeds



DFS Dockable Piston Filling Machine

Removable Trolley, Flexible Design, Wide Range of Filamatic Piston Pump Sizes, Product Viscosities, and Speeds

DFS Dockable Flow Meter Filling Machine
Allows Fluid Metering without Moving Parts, Best Suited for Moderate to Large Fills



DFS Non-Dockable Lobe Filling Machine
Best for Moderate to Large Fills



Proudly built in the U.S.A.

