

DAB Series Semi-Automatic Benchtop



DAB Series
Medium Duty
Benchtop Filler

- Multiple Pumps with Fill Ranges up to 260mL
- Easy to Set-Up, Operate, Clean, and Changeover
- Accommodates Free-Flowing, Semi-Viscous, Viscous, Molten Products, and Product with Particulates
- Durable Stainless Steel Structure
- CE Mark and Air Operated Designs Available
- Ability to Mix and Match Pumps and Nozzles for Optimal Versatility and Flexibility

DAB Series Specifications

Model	Fill Stations	Volts	RPM	Fill Size
DAB-5	2	110V or 220V	Up to 35	1mL to 130mL
DAB-8	2	110V or 220V	Up to 16	1mL to 260mL
DAB-A-8	2	20-25 scfm	Up to 16	1mL to 260mL

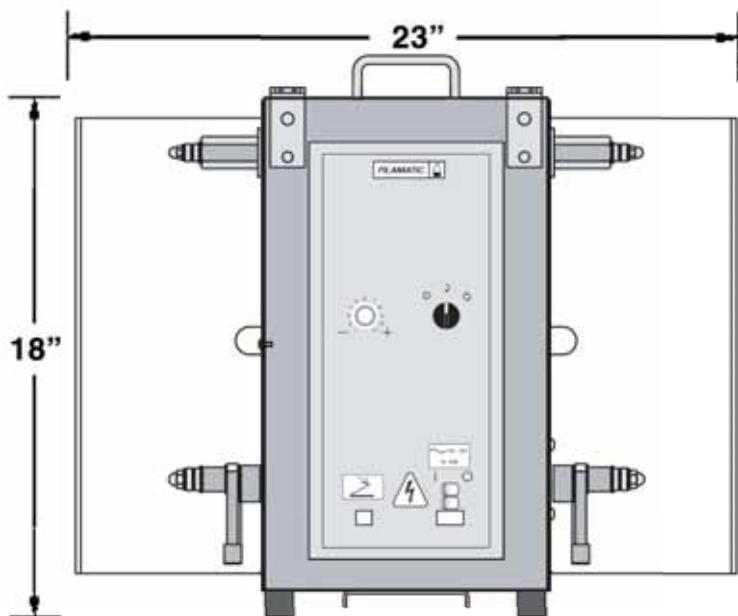

Additional DAB Series Benchtop Features:

- 💧 Fill Accuracy +/- .5%
- 💧 Ideal for Dispensing Separate Liquids into One Container
- 💧 Product May Be Supplied from Floor Level, Overhead, or a Pressurized Source Depending on the Piston Pump Selected
- 💧 Ability to Fill a Wide Range of Containers such as Plastic and Glass Bottles, Pouches, Syringes, and Test Tubes
- 💧 Manufactured in the USA

Filamatic offers COMPLIMENTARY product testing and purchasing options including rentals, lease arrangements, and a "Try Before You Buy" program. For more information call 866.258.1914 or email info@filamatic.com.

